

Location Based Task Reminder System Using Android Mobile

Adarrsh Paul¹, Akkshansh Paul², S.Jaya Kumar³

^{1,2} Student, Department of Computer Engineering, SRM IST, Chennai, Tamil Nadu, India.

³ Assistant Professor, Department of Computer Engineering, SRM IST, Chennai, Tamil Nadu, India.

Abstract – The location based reminder application offers location-based reminders which sends an alert when you get to (or leave) a specific place. The aim is to be able to remind the user of certain tasks which are specific to one point only. People often forget to pick up certain items when they pass right by the grocery shop. The app will allow the user set up a reminder that you need to buy some groceries at your preferred supermarket chain. This app would then request the shop locations from a server and remind you whenever you are, e.g., 200 meters near from the shop. The user can save certain tasks to be done when they are nearby to a specified location and the app will remind the user when they are close to the location. The app is highly recommended for the people who are quite disorganized and forgetful which is quite common in the modern day lifestyle. The app is meant to save the time, increase efficiency and reduce frustration.

Index Terms – Android, Google Map, GPS, Reminder, Smartphones.

1. INTRODUCTION

Nowadays, most of the people are quite busy, in this hectic life style it is very difficult to remember what task to do at what location.

In this era of technology, mobile phones are one of the most fascinating technology that we use the most. Mobile phones have come a long way from just a medium of communication to one of our best mates. Today, it is very difficult to spend even a single day without the mobile. If our phone breaks down, it make us quite nervous.

Nowadays, mobiles come bundled with a lot of features. It's like many of the gadgets are mixed together and made into a single powerful gadget with the main features of all. Mobile serves as an iPod for listening to music, as a digital camera for taking high resolution images, as a handycam for making videos, as a computer for browsing the Internet and playing games, etc. Though it's not as good as using the individual gadgets but still the output is quite satisfying. If the advancement in mobile technology continues at this pace, we might observe new inventions in the field of individual gadgets applied to mobiles as well. This means that the mobile will be as advanced as the individual gadgets it is made up of. Mobiles also support GPS (Global Positioning System) technology. This technology helps in accessing your position, whether you are on foot or in a vehicle. You can easily get to know where

you are located with the help of a map and you can also get to know the way to a particular place with the help of directions that are provided to you. Android sharing the most of the shares in the smartphone business.

Android Programming language on Android operating system as Android provides more flexibility and ease of installing any application developed on it. We included some permission for fetching the location of the user from Android SDK. "Location Based Task Reminder App Using Android". Android was built from the ground-up enabling developers to create compelling mobile applications that take full advantage of all that a handset has to offer. It was built to be truly an open-source. For example, an application can call upon any of the phone's core functionality such as making calls, sending text messages, or using the camera, allowing developers to create richer and more cohesive experiences for users. Android is built on the open Linux Kernel. Furthermore, it utilizes a custom virtual machine that was designed to optimize memory and hardware resources in a mobile environment. Android systems can be liberally extended to incorporate new cutting edge technologies as they emerge. The platform will continue to evolve, as the enthusiastic community of developers work together to build innovative mobile application, with new releases of API with each version.

Google Maps is a web mapping service application and technology provided by Google, that powers many map-based services. Google maps can display map images, topographic maps, satellite images and hybrid images. It can also achieve global location search, classified information access, traffic information queries, driving direction lines and even street scene 3-dimensional view and so on. Android lets the developer to create activities that include interactive Google Maps as part of the user interface, with full access to the maps which the developer can control programmatically and annotate using Android's rich graphics library. Geo-coding is a feature that allows developers to translate between street addresses and latitude-longitude map coordinates. This gives a recognizable context for the locations and co-ordinates used in location-based services and map-based Activities. To combine maps with locations, Android includes an API for forward and reverse geo-coding that lets the user find map co-ordinates for an address, and the address of a map position.

Introduced by Google in 2007, Android is the most popular smartphone operating system in the world as of 2016. Since its release, sales of smartphones running on the Android have grown strongly over the years. In 2009, 6.8 million Android smartphones were sold. By 2015, this figure had risen to more than 1.16 billion. Android accounted for around 85 percent of all smartphone sales to end users worldwide in the beginning of 2016 and reached 87.7% at the ending of 2017. The android smartphones provides Google Map, Google Location services to the smartphones through which we can easily get the location detail but it does not provides the facility to add the task reminder on specific location. By using their services of Map, GPS and Location we developed the system called as "Location Based Task Reminder App Using Android Mobile". This system plays very important role in user's daily life to set task reminder at several locations through which user can make idea and alert of tasks he has to perform on specific location.

There are so many applications on smartphones which provide location based services but they are allow us to set multiple reminder at multiple location through our implemented system we can add multiple reminders on one location. This will help user to improve their daily important activities such as meeting, conference, wedding, party, exam and many more. For marketing and business oriented users it is very beneficial system. We implemented this system using Android Programming language on Android operating system as Android provides more flexibility and ease of installing any application developed on it. We included some permission for fetching the location of the user from Android SDK. "Location Based Task Reminder App Using Android".

2. EXISTING APPROACH

In previous existing approach there was provision to add reminder on a specific location but in that user is able to add the task reminder on the basis of time and date the problem with system was when user crossed the specified location but he was unable to get the task reminder about the location and if he is on another location then task reminder alert is displayed in this way there was no proper synchronization between task reminder and specified location. There was a provision to add one task reminder at one location only which is quite difficult to the user if he has many other tasks to complete on same place.

There are some following drawbacks of existing system:

- 1) Less reliability
- 2) Less location accuracy
- 3) Only one task reminder on one location
- 4) No user friendly and customizable
- 5) Less Ease of access to the application and location

To overcome these drawbacks we proposed the system called "Location Based Task Reminder System Using Android Mobile" which is discussed in the proposed approach.

3. FEATURES OF THE SYSTEM

We included some permission for fetching the location of the user from Android SDK. "Location Based Task Reminder App Using Android" focuses on following features.

- 1) Provides ease of access.
- 2) Quick and easy to handle.
- 3) Provides better reliability.
- 4) Faster access to the location and easily customizable.
- 5) Provide efficient output to the user in terms of reminder of tasks.
- 6) Supports Android Oreo: Works like a charm even with Android Oreo where other similar apps won't work.
- 7) Google Maps directions: Get directions to task location directly from the app.
- 8) Search by Address: Add place reminders by searching for addresses in place picker. This makes setting location reminders a breeze.
- 9) Reusable reminders: Reset reminders easily without adding them again. Saves a lot of effort.

4. PROPOSED SYSTEM

We proposed the system "Location Based Task Reminder System Using Android Mobile" in which we implemented the services which are overcome and solution on the existing approach. In this system user can able to get his current location even he can browse any of location and add task reminder on that particular location through the Android application. When user will reach the specified location through Android application it will check the task reminder's specified location and its latitude and longitude if the task reminder's location is matched with current location of the user the alarm of task reminder will be generated by the Android application. This all activities will be done by using Google map and GPS services.

We used Android programming and operating system for this system which allows easy installation of application. Our proposed system allow user to add many task reminder on the same location and can add multiple task reminder in the application. In our proposed system it doesn't provide continuous reminder to the user it just simply display the task reminder until and unless the user decline that notification, searching of location from current location is very effective in our system when user will search any location and add task reminder on that searched location it will be stored in the Android smartphones database and if user got the alert from

application about task reminder and user decline it or cancel it that will delete from Android smartphones database. It doesn't collect any used records user can add new location task reminder and if he wants to continue with the same location he can also set same task reminder for same location without cancelling it.

5. IMPLEMENTATION AND WORKING

We used android programming language and Android operating system to implement this system, for connectivity with GPS we used Google API [4]. Google map provides service to Android application for adding task reminder on specific location using "Location Based Task Reminder System Using Android Mobile". In given fig.1 there is complete structure of "Location Based Task Reminder System Using Android Mobile".

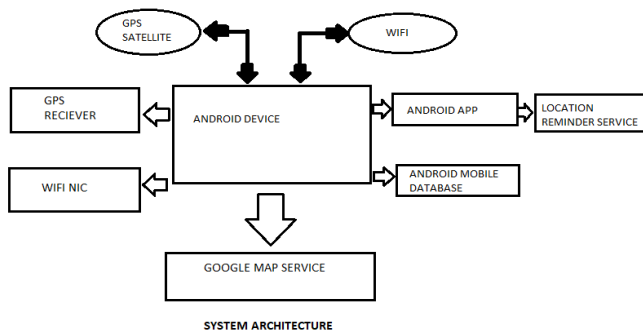

Fig1. Architecture of "Location Based Task Reminder System Using Android Mobile"

When user will connect to the GPS or Wi-Fi an application installed on users Android mobile phone will try to connect to the GPS service. It will fetch location of the user based on users query. There is synchronization with Google Map with our Android application. There is GPS receiver to receive service from GPS and Wi-Fi provides connectivity to the mobile through which user can access any location. Android application allows adding reminder.

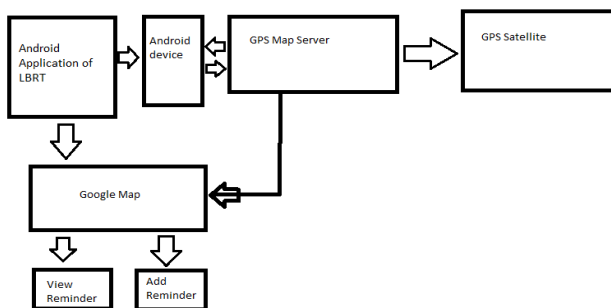

Fig.2. Flow of "Location Based Task Reminder System Using Android Mobile"

In given fig.2 there is flow of "Location Based Task

Reminder System Using Android Mobile". For adding task reminder user need to install our Android application in their mobile phones. User will ask to certain permission while installing it, once it is accepted by the user the Android application is ready to give service to the user. Following are the permissions we add in implementation.

- Android.permission.ACCESS_FINE_LOCATION
- Android.permission.ACCESS_COARSE_LOCATION
- Android.permission.ACCESS_NETWORK_STATE
- Android.permission.ACCESS_MOCK_LOCATION
- Android.permission.ACCESS_WIFI_STATE
- Android.permission.BIND_INPUT_METHOD
- Android.permission.BIND_DEVICE_ADMIN
- Android.permission.BIND_NFC_SERVICE
- Android.permission.BIND_TEXT_SERVICE
- Android.permission.BIND_NFC_SERVICE
- Android.permission.CHANGE_NETWORK_STATE
- Android.permission.ACCESS_WIFI_STATE
- Android.permission.CONTROL_LOCATION_STATE
- Android.permission.INSTALL_LOCATION_PROVIDER

This will give service based on their work. When user will install the application in their Android mobile phones and when user will open it then it will requires location services provided by the Google. User can browse any of location through the Android application and set task reminder on that specified location when user will reach on that location in the future the service installed in users mobile phone provided by our system will match that latitude and longitude and if that specified task reminder's locations latitude and longitude matches with the current location after reaching by the user will be generate an alert as reminder through the Android application in the user's Android mobile phones . This system uses the system database to store the Task reminder set by the user. User can view his current location in the view of satellite, Route, Google earth and in navigation form. User can add multiple task reminders on same location. This system is really beneficial to perform daily routine task more effectively. We registered our Google API key to access the services provided by the Google. In such manner our system provides these features and reliability to the user.

6. EXPERIMENTAL RESULTS

We got the following experimental result after implementing and executing our system. Below fig.3 is the description of after installing our Android application.

We used android programming language and Android operating system to implement this system, for connectivity with GPS we used Google API [4]. Google map provides service to Android application for adding task reminder on specific location using "Location Based Task Reminder System Using Android Mobile". In given fig.1 there is

complete structure of “Location Based Task Reminder System Using Android Mobile.



Fig.3. Home Screen of “Location Based Task Reminder System Using Android Mobile”

When user will install our Android application this screen will be shown to user, as per the above figure it needs some input in the form of string as a location. The given figure is the result when user haven't give any input.

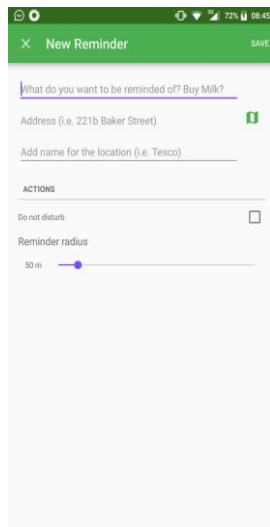

Fig.4 User input some location for task reminder

User has to give some location input in the form of string on which location he has to input his task as a reminder. After that it will fetch his current location and destination location in the form of latitude and longitude and matches it from current location to the destination location of the user, which is shown in next result. We can also set the reminder radius which is the distance at which the app will notify you when you are near a certain location.



Fig.5 View of User's Current Location

User can also view his current location and can set reminder on that current location.



Fig.6 View of Destination Location

User can also change the location from current location to any desired location on which he wants to add reminder. Simply drag the pointer to the desired location or type the address.



Fig.7 View of Successfully Added Reminder

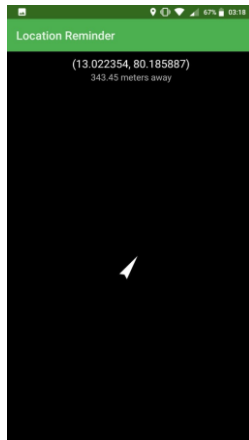

Fig. 8 Update of Location Distance from His Current Location

User can view his required location from his current location in the form of latitude and longitude from which he can guess our location is nearby from current location.

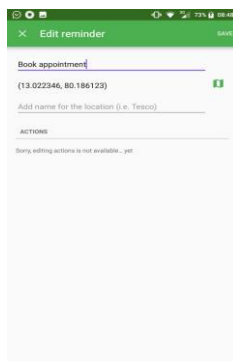

Fig.9 Editing the Reminder

User Can Edit the Reminder According To His Preferences

7. CONCLUSION

Nowadays, most of the people live a very busy life. In this rush they often forget about things that they had to do. People often forget to pick up certain items when they pass right by the grocery shop. With the dawn of mobile world communication. The use of smart phones has shown a steep rise, android being a majority operating system in the smartphones. The app will allow the user set up a reminder that you need to buy some groceries at your preferred supermarket chain. This app would then request the shop locations from a server and remind you whenever you are, e.g., 200 meters near from the shop. The user can save certain tasks to be done when they are nearby to a specified location and the app will remind the user when they are close to the location. It is the location based reminder application offers location-based reminders which sends an alert when you get to (or leave) a specific place. The aim is to be able to remind the user of certain tasks which are specific to one point only. The app is highly recommended for the people who are quite disorganized and forgetful which is quite common in the modern day lifestyle. The app is meant to save the time, increase efficiency and reduce frustration.

REFERENCES

- [1] Reto Mier, "Professional Android Application Development".
- [2] T. Sohn, et al., "Place-Its: A Study of LocationBased Reminders," in UbiComp, 2005, p. 19.
- [3] www.gps.gov/applications/survey
- [4] Reto Mier, "Professional Android Application Development".
- [5] Ruchika Gupta and BVR Reddy GPS and GPRS Based Cost Effective Human Tracking System Using Mobile Phones.
- [6] www.udacity.com/android_courses.
- [7] <https://www.statista.com/statistics/266136/global-market-share-held-by-smartphone-operating-systems>.